

RT 200 | RT 400 | RT 600 | RT 800 - Rotary Dryer

For the Rotary Vibrator

The rotary dryers are suitable for spot-free drying of all types of workpieces. The use of the hot air blower ensures uniform drying of the workpieces and the drying granulate.

Stationary



Straight edges



Contours



RT 200



Accessories on request

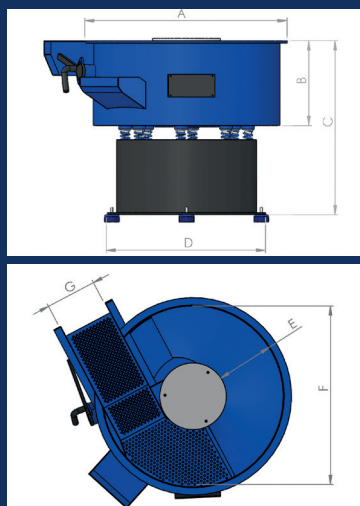

Features

- ✔ Sturdy, long-life construction with plastic-coated steel tub
- ✔ Uniform effect over the entire surface
- ✔ Spotless drying
- ✔ Consistent drying quality
- ✔ Increased service life of the drying granulate through use of the hot air blower
- ✔ Uniform rise of the work tank ensures good circulation and optimum workpiece transport

Options

- ✔ Dry media for individual application
- ✔ Separation flap, optionally manual or automatic
- ✔ Indirect drying

Delivery contents

- ✔ Controller
- ✔ Hot-air blower
- ✔ Separation flap, manual
- ✔ Operating manual

Technical data

	RT 200	RT 400	RT 600	RT 800
Motor	1.1 kW 1,500 rpm	1.1 kW 1,500 rpm	1.1 kW 1,500 rpm	4.0 kW 1,500 rpm
Energy	400 V, 50 Hz	400 V, 50 Hz	400 V, 50 Hz	400 V, 50 Hz
Tub diameter (F= Ø)	1000 mm	1200 mm	1400 mm	1420 mm
Tub internal dimensions F×E×B)	1000 x 315 x 440 mm	1200 x 380 x 500 mm	1400 x 460 x 550 mm	1420 x 530 x 630 mm
Dimensions (A x C)	1080 x 1010 mm	1280 x 1080 mm	1480 x 1180 mm	1500 x 1130 mm
Max. Heating power	1000W	1000W	1600W	2400W
Temperature for the corn granules	50°	50°	50°	50°
Weight	350 kg	480 kg	570 kg	920 kg
Item no.	67689	68015	67879	67374